



TECHNICAL SPECIFICATIONS

POST SCREEN	PRE SCREEN OPTION		
	12x5 Linear Screen	12x5 2 Deck Incline	14x6 Linear Screen
8x4 Linear Screen	✓	✓	✗
12x5 Linear Screen	✓	✓	✓
12x5 2 Deck Incline	✓	✓	✗
12x5 3 Deck Incline	✓	✓	✓

In the attached infographic you can see an outline of all the Pre and Post Screen Options and the various combinations that can be achieved.

In terms of Trash Screen every plant combination can be fitted with either 6x2 or an 8x4 Trash Screen. This will be driven by the % and type of trash that is within the Feed Material





AGGSTORM 150 HULL

Hull Width	2140mm (7')
Hull Length	7330mm (24')
Drive Mechanism	Belt Driven Direct Gearbox & Chain Coupling
Electrical Motors	2x 22kW
No. Spray Nozzles	20 x 7mm Rinser Spray Nozzles
	16 x 10mm Drilled Outlets
Shaft RPM	17 – 22 RPM (VSD Supplied Standard)
Hull Incline Angle	8 Degrees
Shaft Wall Thickness	19mm
Shaft Options	Helical Blade Orientation (xx No Blades / shaft) Straight Blade Orientation (xx No Blades / shaft)
Blade Options	Hardox (Item 1) 13% Manganese (Item 2) High Chromium (Item 3)
Hull Access	5 Large Access Doors per Side Open Top Hull (Removeable Mesh)
Wear Liners	Rubber Lined Chute Work Material Build up to Line Hull
Water Level Adjustment	Using Removable Dam Bars at Hull Outlet



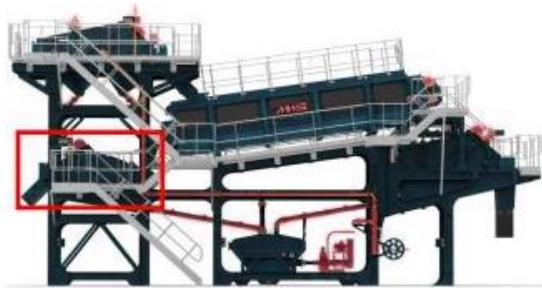

Trash Screen is located at the back end of the hull. Its purpose is to deal with any woods, plastics, or light material that weirs off the back of the logwasher, dewater the trash material and discharge into a bay or skip to improve the quality of the end product

6x2 DEWATERING SCREEN

Screen width	1200mm (4')
Screen length	2400mm (8')
Drive	Electric Vibrating Motors
Motor	2 x 2.69kW (3.6hp)
Speed	900 RPM
Media Type Options	WS85 Polyurethane Panels

8x4 DEWATERING SCREEN

Screen width	1200mm (4')
Screen length	2400mm (8')
Drive	Electric Vibrating Motors
Motor	2 x 2.69kW (3.6hp)
Speed	900 RPM
Media Type Options	WS85 Polyurethane Panels

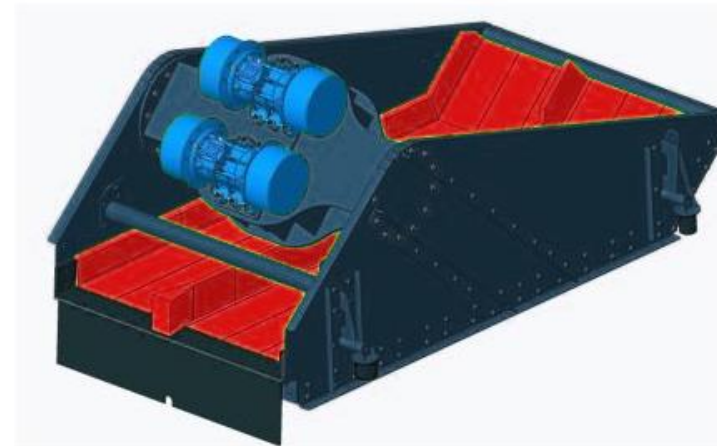
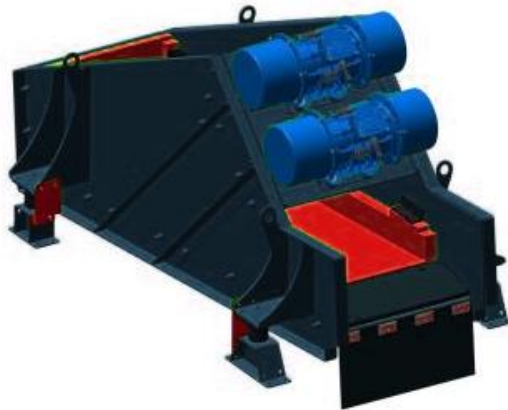



The Pre Screen is a primary rinsing screen before material enters the Logwasher hull. Material going to this screen will have passed through a tipping grid, or a scalping screen to size at 100mm (-4") On this screen the material will be rinsed to remove the majority of -5mm material. Reducing the amount of 5mm in the log washer hull is imperative to increase the function of stone on stone attrition for scrubbing the material & also reducing wear on the blades

12x5 LINEAR PRE SCREEN

Screen width	1500mm (5')
Screen length	3600mm (12')
Drive	Electric Vibrating Motors
Motor	2 x 4.5kW (6hp)
Speed	900 RPM
Media Type Options	WS85 Polyurethane Panels
No. of Spray Nozzles	30

14x6 LINEAR PRE SCREEN

Screen width	1800mm (6')
Screen length	4200mm (14')
Drive	Electric Vibrating Motors
Motor	2 x 8.3kW (11hp)
Speed	900 RPM
Media Type Options	WS85 Polyurethane Panels
No. Of Spray Nozzles	43

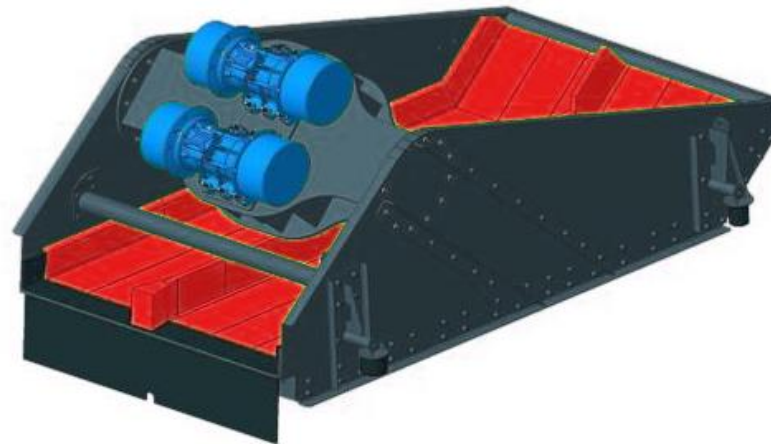



The Pre Screen is a primary rinsing screen before material enters the Logwasher hull. Material going to this screen will have passed through a tipping grid, or a scalping screen to size at 100mm (-4") On this screen the material will be rinsed to remove the majority of -5mm material. Reducing the amount of 5mm in the log washer hull is imperative to increase the function of stone on stone attrition for scrubbing the material & also reducing wear on the blades



12x5 2 DECK INCLINE PRE SCREEN

Screen width	1525mm (5')
Screen length	3600mm (12')
Drive	Belt and Pulley System
Motor	11kW (15hp)
Media Type	Side Tensioned Wire Mesh
Media Panel Size	1525 x 1220mm (5'x4')
Screen Incline Angle	18 Degrees
Discharge Chute	Hardox Lined Roll in Chute
Oversize Discharge Conveyor	8m x 650mm (26' x 26")
Conveyor Drive Motor	4kW (5hp)



After passing through the Logwasher Hull, the cleaned Aggregate is transferred onto a second screen. There are a number of different options for this screen. The single deck screens are used for rinsing the material before transferring onto a secondary sizing screen. The incline screens are used for sizing and rinsing directly from material discharge of the log washer hull. Further information on material flows can be found in the flow sheets later in this document

8x4 LINEAR RINSING SCREEN

Screen width	1200mm (4')
Screen length	2400mm (8')
Drive	Electric Vibrating Motors
Motor	2 x 2.69kW (3.6hp)
Speed	900 RPM
Media Type Options	WS85 Polyurethane Panels
No. Of Spray Nozzles	10

12x5 LINER RINSING SCREEN

Screen width	1500mm (5')
Screen length	3600mm (12')
Drive	Electric Vibrating Motors
Motor	2 x 4.5kW (6hp)
Speed	900 RPM
Media Type Options	WS85 Polyurethane Panels
No. of Spray Nozzles	14

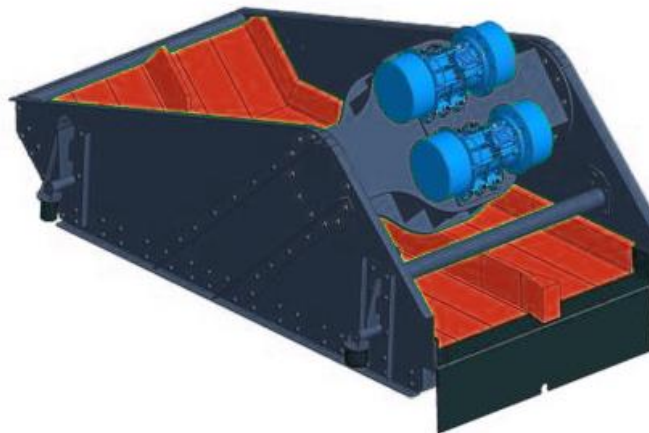



After passing through the Logwasher Hull, the cleaned Aggregate is transferred onto a second screen. There are a number of different options for this screen. The single deck screens are used for rinsing the material before transferring onto a secondary sizing screen. The incline screens are used for sizing and rinsing directly from material discharge of the log washer hull. Further information on material flows can be found in the flow sheets later in this document



12x5 2 DECK INCLINE PRE SCREEN

Screen width	1525mm (5')
Screen length	3600mm (12')
Drive	Belt and Pulley System
Motor	11kW (15hp)
Media Type	Side Tensioned Wire Mesh
Media Panel Size	1525 x 1220mm (5'x4')
No. of Spray Nozzles	20
Screen Incline Angle	18 Degrees
Discharge Chute	Hardox Lined Roll in Chute
Oversize Discharge Conveyor	8m x 650mm (26' x 26")
Conveyor Drive Motor	4kW (5hp)



North American Headquarters

1 McCloskey Road, Keene, Ontario, K9J 0G6, Canada
T: 1 (705) 295-4925
F: 1 (705) 295-4777
E: sales@mwswashing.com
W: www.mwswashing.com

European Headquarters

47 Moor Road, Coalisland, Co. Tyrone, BT71 4QB, N. Ireland
T: +44 (0) 28 87 740 926
F: +44 (0) 28 87 747 242
E: sales@mwswashing.com
W: www.mwswashing.com

A Division of McCloskey International

McCloskey International reserves the right to make changes to the information and design of the machines detailed within this technical specification, without reservation and notification to the users. McCloskey International assumes no liability resulting from error or omissions in this document.

© Copyright McCloskey International 2020. All rights reserved.