

SALES PACK INFORMATION



S-Range Rinsers

Key Information

Key Features

Mobile washing plant
Fast set up time
Low cost set up – No crane required
Easily converted to dry screen mode
Extra coupling facility to run additional equipment (stackers or sandscrew for example)

Dimensions and Weights

Transport length – 18.2m (59' 8")
Transport width – 3.22m (10' 7")
Transport height – 3.45m (11' 4")
Weight – 36,500 Kgs (80,468 lbs est.)

Options

2 or 3 Deck
Crusher chute (available with 15ft hopper only)
Dual power
Roll-in bogie system
Single or double deck live head
Tail conveyor
Wheel or tracked machine

Average Water Requirements

2 Deck – 4100 litres/min (245m³/h)
3 Deck – 6100 litres/min (365m³/h)



Screenbox
 2 or 3 deck option
 Polyurethane modular mats or woven wire screen media options
 Dimensions – top deck 20' x 5' (6100mm x 1524mm)
 Dimensions – middle deck 20' x 5' (6100mm x 1524mm)
 Dimensions – bottom deck 18' x 5' (5490mm x 1524mm)
 Adjustable screen stroke (6-10mm max)
 Access walkways on screen maintenance
 Screen angle 20 to 30 degree (20degree optimum)

Rinsing Kit
 8 Independently controlled spray bars on each deck
 60 Spray nozzles per deck
 6" Diameter (150mm) main water supply pipe

Main conveyor
 41" (1050mm) wide belt
 Variable working angle
 Variable speed option

Side Conveyors
 Stockpile height 16' 9" (5100mm)
 32" (800mm) wide belt
 Variable speed

Feed/Hopper
 Large capacity 15ft hopper 13.09yd³ (10m³)
 Radio controlled tipping grid
 Grid spacing 4" (100mm)
 Variable speed belt feeder
 Variable grid option



Catchbox
 Hydraulic lift/lower of catchbox to aid mesh change/maintenance
 Catchbox is fully rubber lined
 Quick change system from catchbox to tail conveyor
 Single or double outlet options
 Various catchbox division plate options

Power Unit
 Engine CAT 4.4
 Engine power 131hp
 Engine speed 2200rpm
 Hydraulic oil cooler
 Fuel consumption approx. 15litre/hour
 Diesel tank capacity 399 litres (105 US gal)

Tracks
 19.7" (500mm) wide
 Max speed 1.14kph (0.71mph)
 Bolt on to chassis for quick change

Auxiliary Conveyor
 Stockpile height 15' 5" (4700mm)
 26" (650mm) wide belt
 Variable speed

Sales Drawings

This is based on a typical pairing between an S190 3-deck 2-sand unit, and a CSP12-2 grade.

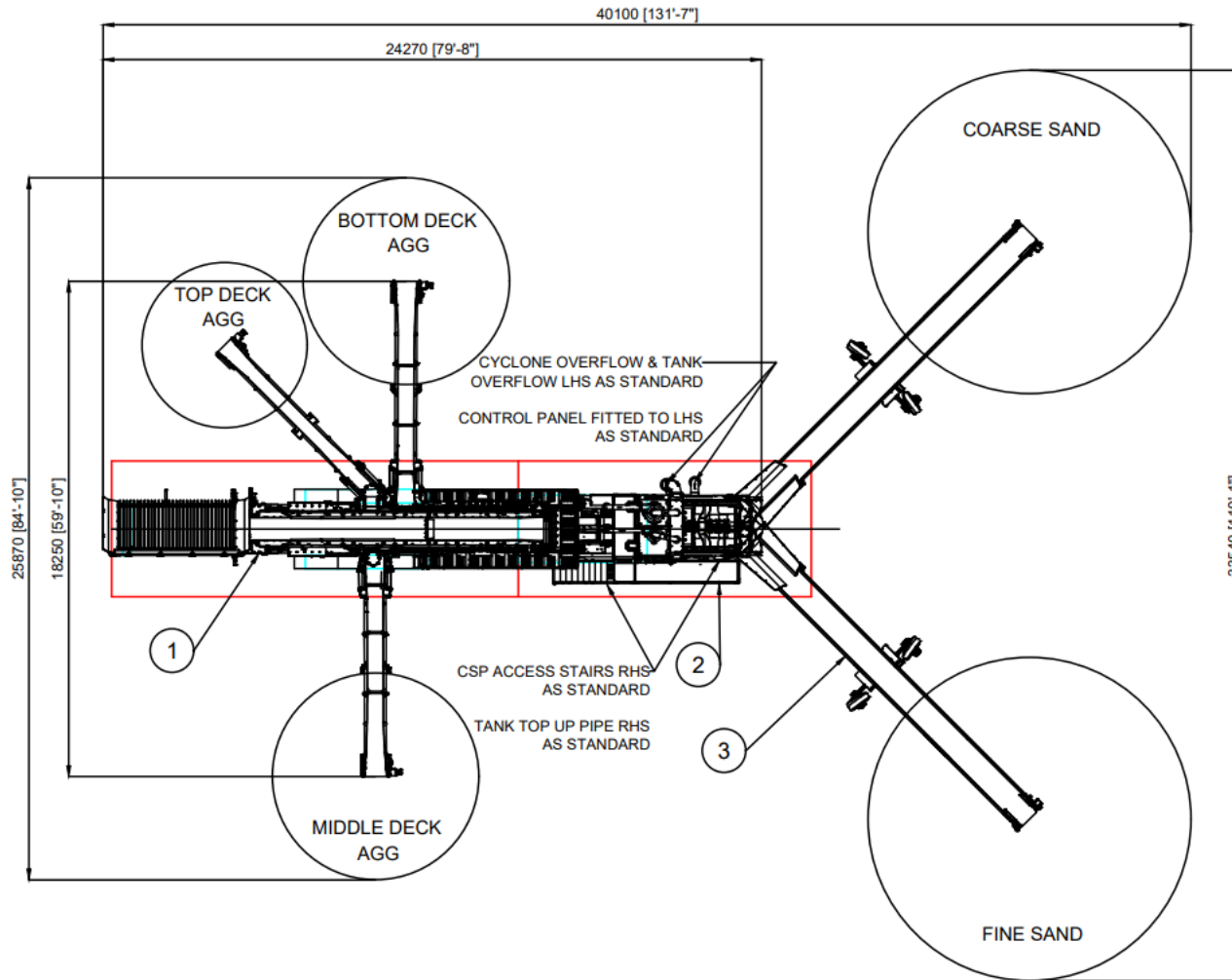

DETAIL A

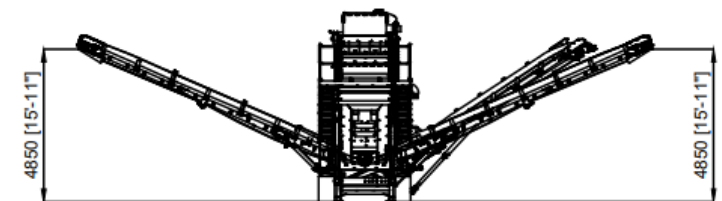
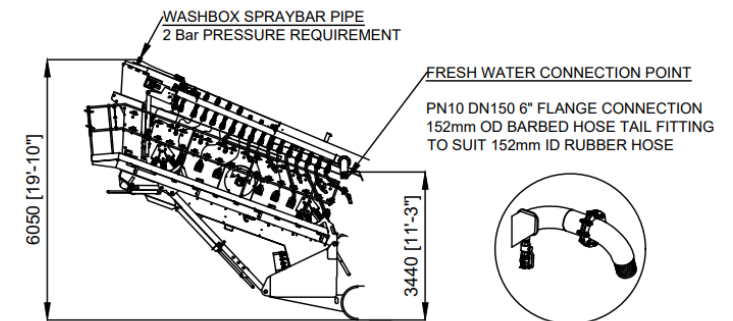

Sales Drawings

This is based on a typical pairing between an S190 3-deck 2-sand unit, and a CSP12-2 grade (continued)

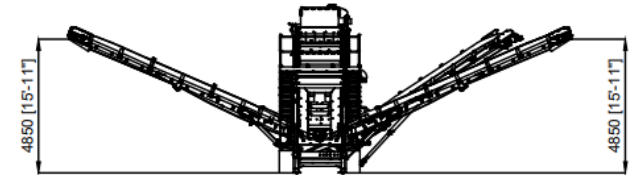
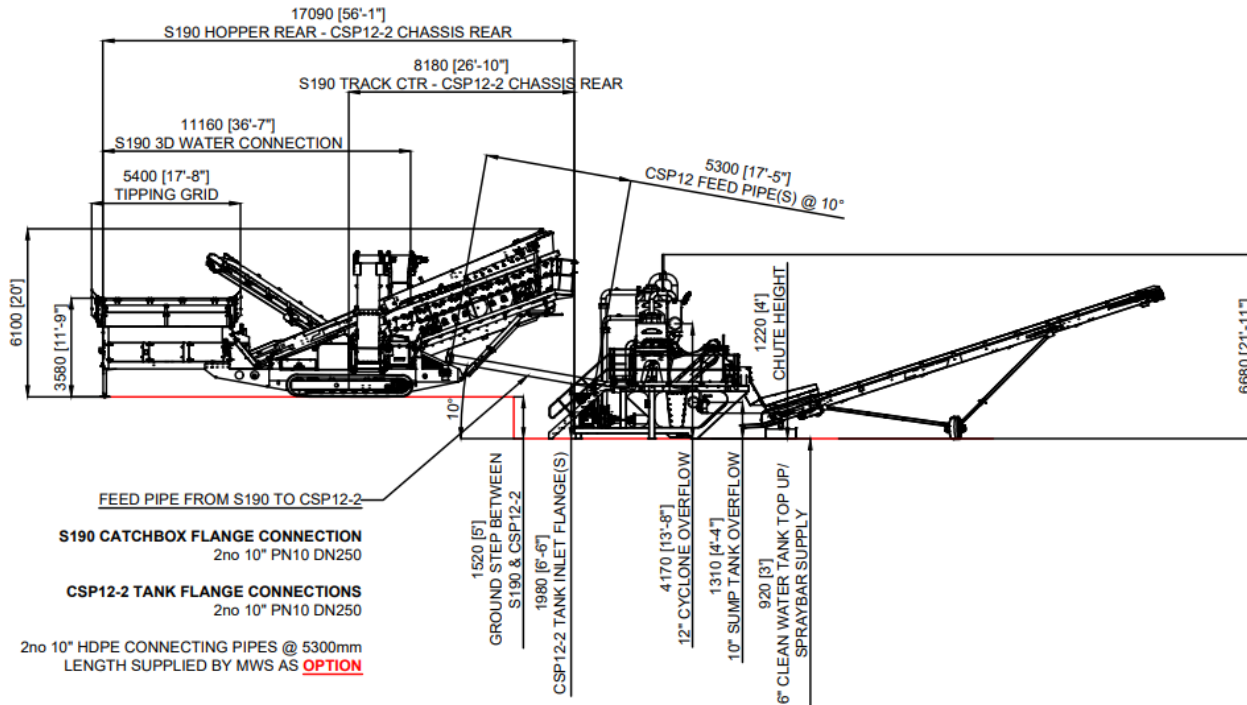



North American Headquarters

1 McCloskey Road, Keene, Ontario, K9J 0G6, Canada
T: 1 (705) 295-4925
F: 1 (705) 295-4777
E: sales@mwswashing.com
W: www.mwswashing.com

European Headquarters

47 Moor Road, Coalisland, Co. Tyrone, BT71 4QB, N. Ireland
T: +44 (0) 28 87 740 926
F: +44 (0) 28 87 747 242
E: sales@mwswashing.com
W: www.mwswashing.com

A Division of McCloskey International

McCloskey International reserves the right to make changes to the information and design of the machines detailed within this technical specification, without reservation and notification to the users. McCloskey International assumes no liability resulting from error or omissions in this document.

© Copyright McCloskey International 2020. All rights reserved.